



USER MANUAL

# VIA AMOS-825

Fanless ultra-compact quad-core  
ARM system ruggedized for demanding  
transportation environments



## Copyright

Copyright © 2016-2019 VIA Technologies Incorporated. All rights reserved.

No part of this document may be reproduced, transmitted, transcribed, stored in a retrieval system, or translated into any language, in any form or by any means, electronic, mechanical, magnetic, optical, chemical, manual or otherwise without the prior written permission of VIA Technologies, Incorporated.

## Trademarks

All trademarks are the property of their respective holders.

## Disclaimer

No license is granted, implied or otherwise, under any patent or patent rights of VIA Technologies. VIA Technologies makes no warranties, implied or otherwise, in regard to this document and to the products described in this document. The information provided in this document is believed to be accurate and reliable as of the publication date of this document. However, VIA Technologies assumes no responsibility for the use or misuse of the information (including use or connection of extra device/equipment/add-on card) in this document and for any patent infringements that may arise from the use of this document. The information and product specifications within this document are subject to change at any time, without notice and without obligation to notify any person of such change.

VIA Technologies, Inc. reserves the right to make changes to the products described in this manual at any time without prior notice.

## Regulatory Compliance

### FCC-A Radio Frequency Interference Statement

This equipment has been tested and found to comply with the limits for a class A digital device, pursuant to part 15 of the FCC rules. These limits are designed to provide reasonable protection against harmful interference when the equipment is operated in a commercial environment. This equipment generates, uses, and can radiate radio frequency energy and, if not installed and used in accordance with the instruction manual, may cause harmful interference to radio communications. Operation of this equipment in a residential area is likely to cause harmful interference, in which case the user will be required to correct the interference at his personal expense.

### FOR PORTABLE DEVICE USAGE (<20m from body/SAR needed)

#### Radiation Exposure Statement:

The product complies with the FCC portable RF exposure limit set forth for an uncontrolled environment and are safe for intended operation as described in this manual. The further RF exposure reduction can be achieved if the product can be kept as far as possible from the user body or set the device to lower output power if such function is available.

### FOR MOBILE DEVICE USAGE (>20cm/Low power)

#### Radiation Exposure Statement:

This equipment complies with FCC radiation exposure limits set forth for an uncontrolled environment. This equipment should be installed and operated with minimum distance 20cm between the radiator & your body.

### Notice 1

The changes or modifications not expressly approved by the party responsible for compliance could void the user's authority to operate the equipment.

### Notice 2

Shielded interface cables and A.C. power cord, if any, must be used in order to comply with the emission limits.

### Notice 3

The product described in this document is designed for general use, VIA Technologies assumes no responsibility for the conflicts or damages arising from incompatibility of the product. Check compatibility issue with your local sales representatives before placing an order.



Tested To Comply  
With FCC Standards  
FOR HOME OR OFFICE USE



## Battery Recycling and Disposal

- Only use the appropriate battery specified for this product.
- Do not re-use, recharge, or reheat an old battery.
- Do not attempt to force open the battery.
- Do not discard used batteries with regular trash.
- Discard used batteries according to local regulations.



## Safety Precautions

- Always read the safety instructions carefully.
- Keep this User's Manual for future reference.
- All cautions and warnings on the equipment should be noted.
- Keep this equipment away from humidity.
- Put this equipment on a reliable flat surface before setting it up.
- Check the voltage of the power source and adjust to 110V/220V before connecting the equipment to the power inlet.
- Do not place the power cord where people will step on it.
- Always unplug the power cord before inserting any add-on card or module.
- If any of the following situations arise, get the equipment checked by authorized service personnel:
  - The power cord or plug is damaged.
  - Liquid has entered into the equipment.
  - The equipment has been exposed to moisture.
  - The equipment is faulty or you cannot get it work according to User's Manual.
  - The equipment has been dropped and damaged.
  - The equipment has an obvious sign of breakage.
- Do not leave this equipment in extreme temperatures or in a storage temperature above 60°C (140°F). The equipment may be damaged.
- Do not leave this equipment in direct sunlight.
- Never pour any liquid into the opening. Liquid can cause damage or electrical shock.
- Do not place anything over the power cord.
- Do not cover the ventilation holes. The openings on the enclosure protect the equipment from overheating

### WARNING:

The operating temperature of VIA AMOS-825 is from 0°C to 60°C, please must installed the device in a restricted access location to avoid the hot surface of housing, and make more aware of potential hazards and reduce the risk.



## Box Contents

- 1 x VIA AMOS-825 system
- 1 x Phoenix plug to DC jack
- 1 x COM/CAN conversion cable
- 1 x Wi-Fi/BT antenna
- 1 x GPS antenna
- 1 x SCSI 50-pin connector cable
- 1 x Screw pack for mounting
- 1 x Rubber feet pack

## Ordering Information

Part Number	Description
AMOS-825-1Q10A2	Fanless embedded system with 1.0GHz NXP i.MX 6Quad Cortex-A9 SoC, 1GB DDR3 RAM, 16GB eMMC, 4MB SPI Flash ROM, SCSI 50-pin D-sub connector, Mic-in, COM, CAN bus, Micro USB 2.0 OTG port, Wi-Fi, Bluetooth 4.0, GPS, 2 USB 2.0, Gigabit Ethernet, Micro SD card slot, miniPCIe slot, and 9~36V DC-in

## Optional Accessories

### Touch Monitors

Part Number	Description
99G73-010229	7" Projective capacitive touch monitor (800x480, -20°C ~ 70°C)

### Wireless Accessories

Part Number	Description
EMIO-2550-00A1	3.75G HSPA/UMTS mobile broadband full-size miniPCIe module with GPS, SIM card slot, assembly kit and antenna (Note: GPS function is not supported - VIA AMOS-825 already includes GPS support)

## Table of Contents

<b>1. Product Overview</b>	<b>1</b>
1.1. Key Features	1
1.1.1. High-Performance	1
1.1.2. Fanless, Compact, Ruggedized Chassis	1
1.1.3. Support for a Wide Range of Power Sources	1
1.1.4. Wide Range of Operating Temperatures	1
1.1.5. Built-in Intelligent Vehicle Power Management	1
1.1.6. Optimize Integration with Multiple I/O Access	1
1.1.7. Storage Expansion	1
1.1.8. Shock and Vibration Resistant	2
1.1.9. Networking Option	2
1.1.10. Multiple Mounting Option	2
1.1.11. Embedded Operating System Ready	2
1.2. Product Specifications	3
1.3. Layout Diagram	6
1.4. Product Dimensions	7
<b>2. External I/O Pin Descriptions and Functionality</b>	<b>8</b>
2.1. DC-in Jack	8
2.2. Reset Button	8
2.3. LED Indicators	8
2.4. Mic-in Jack	9
2.5. SCSI 50-Pin D-Sub Connector	9
2.6. Micro USB 2.0 OTG Port	10
2.7. COM/CAN Port	10
2.8. USB 2.0 Ports	11
2.9. Gigabit Ethernet Port	11
<b>3. Onboard I/O</b>	<b>12</b>
3.1. MiniPCIe Slot	12
3.2. Micro SD Card Slot	13
3.3. Boot Switch	13
<b>4. Hardware Installation</b>	<b>14</b>
4.1. Installing the GPS and Wi-Fi/BT antennas	14
4.2. Installing the Micro SD card	15
4.3. Installing the rubber feet	17
4.4. Installing the COM/CAN Conversion Cable	18
4.5. Mounting the VIA AMOS-825	20
<b>5. Software and Technical Support</b>	<b>21</b>
5.1. Android Support	21
5.2. Technical Support and Assistance	21
<b>Appendix A. Installing Touch Monitor</b>	<b>22</b>
A.1. Connecting 7" Projective capacitive touch monitor	22
A.2. Unplugging the monitor's cable	24
<b>Appendix B. Installing Wireless Accessories</b>	<b>25</b>
B.1. Installing the VIA EMIO-2550 Mobile Broadband Module	25

## List of Figures

Figure 1: Front panel I/O layout .....	6
Figure 2: Back panel I/O layout.....	6
Figure 3: Dimensions of the VIA AMOS-825 (front view) .....	7
Figure 4: Dimensions of the VIA AMOS-825 (rear view).....	7
Figure 5: Dimensions of the VIA AMOS-825 (top view).....	7
Figure 6: DC-in jack diagram.....	8
Figure 7: Reset button diagram .....	8
Figure 8: LED indicator diagram.....	8
Figure 9: Mic-in jack receptacle diagram .....	9
Figure 10: SCSI 50-pin D-sub connector diagram .....	9
Figure 11: Micro USB 2.0 OTG port diagram.....	10
Figure 12: COM/CAN port diagram.....	10
Figure 13: USB 2.0 port diagram.....	11
Figure 14: Gigabit Ethernet port diagram .....	11
Figure 15: MiniPCIe slot diagram .....	12
Figure 16: Micro SD card slot diagram.....	13
Figure 17: Boot switch diagram.....	13
Figure 18: Installing the GPS and Wi-Fi/BT antennas .....	14
Figure 19: Securing the GPS and Wi-Fi/BT antennas .....	14
Figure 20: Unscrewing the bottom window plate cover.....	15
Figure 21: Removing the bottom window plate cover .....	15
Figure 22: Inserting the Micro SD card.....	16
Figure 23: Installing the rubber feet .....	17
Figure 24: Installing the COM/CAN conversion cable.....	18
Figure 25: Mounting the VIA AMOS-825.....	20
Figure 26: Connecting the other end of the monitor's cable to the touch monitor.....	22
Figure 27: Connecting the monitor's cable to the VIA AMOS-825 system.....	23
Figure 28: Unlocking the monitor's cable head .....	24
Figure 29: Unplugging the monitor's cable head .....	24
Figure 30: Inserting the VIA EMIO-2550 module .....	25
Figure 31: Securing the VIA EMIO-2550 module .....	25
Figure 32: Unscrewing the front panel I/O plate.....	26
Figure 33: Removing the hex standoff screws .....	26
Figure 34: Removing the front panel I/O plate and the antenna hole cover .....	27
Figure 35: Installing the 3G antenna .....	27
Figure 36: Connecting the 3G antenna cable to the micro-RF connector .....	28
Figure 37: Reinstalling the bottom window plate cover .....	28

## List of Tables

Table 1: DC-in jack pinouts .....	8
Table 2: SCSI 50-pin D-sub connector pinouts .....	9
Table 3: Micro USB 2.0 OTG port pinouts.....	10
Table 4: COM/CAN port pinouts.....	10
Table 5: USB 2.0 ports pinouts.....	11
Table 6: Gigabit Ethernet port pinouts .....	11
Table 7: Gigabit Ethernet port LED color definition.....	11
Table 8: MiniPCle slot pinouts.....	12
Table 9: Micro SD card slot pinouts.....	13
Table 10: CAN1 bus port pinouts.....	18
Table 11: CAN2 bus port pinouts.....	19
Table 12: COM debug port pinouts.....	19

# 1. Product Overview

The VIA AMOS-825 is a compact, rugged and completely fanless embedded system designed specifically for in-vehicle system management application to provide a convenient and simplified solution for demanding transportation environments. The VIA AMOS-825 system can be used for various purposes such as infotainment, telematics, fleet management, and taxi dispatching because of its wireless protocols that serves to provide necessary connectivity for maintaining proper communication with a dispatch center.

Based on the Pico-ITX board form factor, the VIA AMOS-825 is powered by 1.0GHz NXP i.MX 6Quad Cortex-A9 processor, and it is completely compatible with Android 6.0 operating system. It also has an onboard 16GB eMMC storage, pre-installed Wi-Fi/BT module, and GPS module for wireless connectivity ready.

The VIA AMOS-825 supports high computing power operation with low power consumption, and it has a built-in power management system that protects from power surges – guarding against damage from transient car power. With the power management system, it is capable of handling a wide ranged DC power inputs from 9V~36V.

The VIA AMOS-825 supports dual-sided multiple I/O connectors such as SCSI, Mic-in, Micro USB 2.0 OTG, CAN/COM, Gigabit Ethernet, USB 2.0, Wi-Fi/BT, and GPS. It also has an onboard Micro SD card slot for flexible storage, and a miniPCIe slot intended for 3G module for expansive wireless connectivity option.

The VIA AMOS-825's system chassis is a robust aluminum alloy that can withstand a wide operating temperature range, and it is designed to support mounting to a floor bed or side-panel of a vehicle.

## 1.1. Key Features

### 1.1.1. High-Performance

With a NXP i.MX 6Quad Cortex-A9 SoC, the ARM based system VIA AMOS-825 delivers powerful performance to a host of connected device applications.

### 1.1.2. Fanless, Compact, Ruggedized Chassis

The VIA AMOS-825 features fanless operation in a sealed ruggedized aluminum chassis that does double duty as a thermal solution. The compact chassis design makes it suitable to install in space critical environment and ensures maximum reliability.

### 1.1.3. Support for a Wide Range of Power Sources

It supports a wide range of input power from 9V to 36V DC. The flexibility of power input enables the VIA AMOS-825 to be deployable for various automation environments.

### 1.1.4. Wide Range of Operating Temperatures

The VIA AMOS-825 carries a qualified thermal performance design which allows a wide range of operating temperatures making it suitable for space and environment critical applications.

### 1.1.5. Built-in Intelligent Vehicle Power Management

The VIA AMOS-825 has an integrated power management system that protects from power surges and transient car power.

### 1.1.6. Optimize Integration with Multiple I/O Access

Front and back panel I/O access enables the VIA AMOS-825 to easily support various applications as well as for easy integration and quick setup.

### 1.1.7. Storage Expansion

The Micro SD card slot enables the VIA AMOS-825 to have a flexible storage of Micro SD card memory.



### 1.1.8. Shock and Vibration Resistant

Shock resistant to 70G, and vibration to 7Grms for maximum reliability.

### 1.1.9. Networking Option

It is equipped with Gigabit Ethernet port, Wi-Fi/BT and GPS modules that support wire and wireless connectivity. It also has additional wireless networking option that gives the system a freedom of 3G connectivity through miniPCIe slot.

### 1.1.10. Multiple Mounting Option

Support multiple methods for mounting the chassis securely. The rugged embedded system can be mounted to a side-panel of a car, floor bed, or any flat surface.

### 1.1.11. Embedded Operating System Ready

The VIA AMOS-825 features a complete evaluation image featuring Android 6.0 operating system.

## 1.2. Product Specifications

### Processor

- 1.0GHz NXP i.MX 6Quad ARM Cortex-A9 SoC

### System Memory

- 1GB DDR3 SDRAM onboard

### Storage

- 16GB eMMC Flash memory

### Boot Loader

- 4MB SPI Flash ROM

### Graphics

- Vivante GC2000 GPU
  - Three independent, integrated 3D/2D and video graphics processing units
  - Graphics engine supporting OpenGL<sup>®</sup> ES 2.0, OpenCL and OpenVG<sup>™</sup> 1.1 hardware acceleration
  - Support MPEG-2, VC-1 and H.264 video decoding up to 1080p
  - Supports SD encoding

### LAN

- Micrel KSZ9031RNX Gigabit Ethernet transceiver with RGMII support

### Wi-Fi/BT and GPS

- IEEE 802.11b/g/n Wi-Fi
- Bluetooth 4.0
- MAX-7 u-blox 7 GPS/GNSS

### Audio

- NXP SGT5000 low power stereo codec

### USB

- SMSC USB2514 USB 2.0 high-speed 4-port hub controller

### CAN

- TI SN65HVD1050 EMC optimized CAN transceiver

### Front Panel I/O

- 1 x Reset button
- 1 x Power LED
- 1 x WPAN/WWAN/WLAN LED
- 1 x SCSI 50-pin D-sub connector (supports backlight power, Dual-channel LVDS, four GPIO, I<sup>2</sup>C, Line-out and Mic-in)
- 1 x COM/CAN port (supports two CAN bus and one COM TX/RX for debug)
- 1 x Micro USB 2.0 OTG port
- 1 x Mic-in jack
- 1 x Antenna hole
- 1 x 4-pole Phoenix DC jack

### Back Panel I/O

- 1 x Gigabit Ethernet port
- 2 x USB 2.0 ports
- 2 x Antenna connectors for Wi-Fi/BT and GPS

### Bottom Side (open window with removable cover)

- 1 x miniPCIe slot
- 1 x Micro SD card slot (supports up to 32GB)
- 1 x Boot switch

### Watchdog Timer

- Integrated watch dog timer supporting two comparison points.  
First comparison point can interrupt ARM core, and the second comparison point is capable of generating external interrupts on WDOG line

### Power Supply

- **Input Voltage**
  - 9V ~ 36V DC
- **Power Consumption**
  - Typical: 7W
- **Intelligent Vehicle Power Management**
  - Ignition on/off power management with hardware configurable delay time:
    - The default power on delay is 5 seconds
    - The default power off delay is 90 seconds
  - System power protection function:
    - Supports input Over-Voltage Protection (OVP): Power (+12V) off when Input Voltage is higher than +38V ( $\pm 2\%$ )
    - Supports Over-Current Protection (OCP): Power (+12V) off when output Over-Current range is 4.5A ~ 5.5A
    - Supports Short-Voltage Protection (SVP): Output Voltage Power (+12V) off when the output voltage is shorted.

### Mechanical Characteristics

- **Construction**
  - Aluminum alloy top chassis housing
  - Metal chassis housing
  - Dual removable front and rear metal face plate
  - Bottom opening cover (open window with removable door plate to access Micro SD card slot, miniPCIe slot and boot switch)
- **Dimension (W x H x D)**
  - 150.5mm x 48.1mm x 103.3mm (5.9" x 1.9" x 4.1")
- **Weight**
  - 0.673kg (1.48lbs)

### Mounting

- Wall/DIN Rail/VESA mountable

### Environmental Specification

- **Operating Temperature**
  - 0°C ~ 60°C
- **Operating Humidity**
  - 0% ~ 90% @ 45°C (non-condensing)

- **Vibration Loading during Operation (with onboard eMMC)**
  - 7Grms, IEC 60068-2-64, random, 5 ~ 500Hz, 1hr/axis
- **Shock During Operation (with onboard eMMC)**
  - 70G, IEC 60068-2-27, half size, 11ms duration

#### Compliance

- CE, FCC

#### Operating System

- Android 6.0



#### Notes:

1. As the operating temperature provided in the specifications is a result of testing performed in VIA's chamber, a number of variables can influence this result. Please note that the working temperature may vary depending on the actual situation and environment. It is highly suggested to execute a solid testing program and take all the variables into consideration when building the system. Please ensure that the system runs well under the operating temperature in terms of application.
2. Please note that the lifespan of the onboard eMMC memory chip may vary depending on the amount of access. More frequent and larger data access on the eMMC memory makes its lifespan shorter. Therefore, it is highly recommended to use a replaceable external storage (e.g., Micro SD card) for large data access.

### 1.3. Layout Diagram

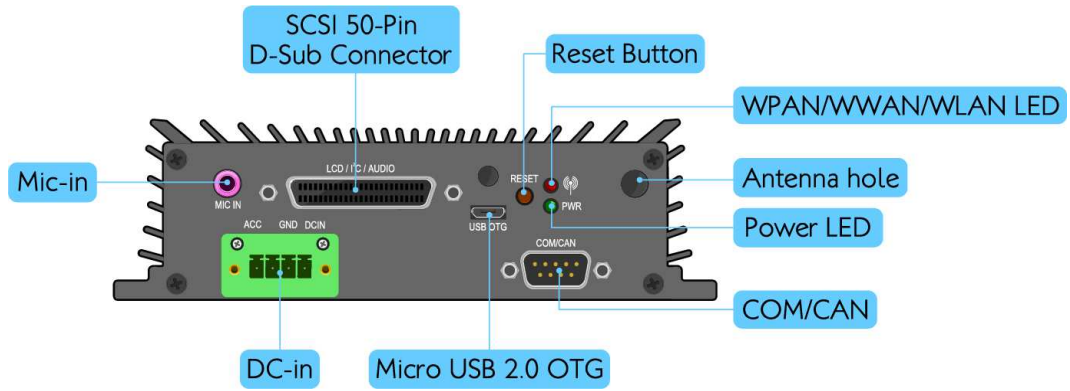

Figure 1: Front panel I/O layout

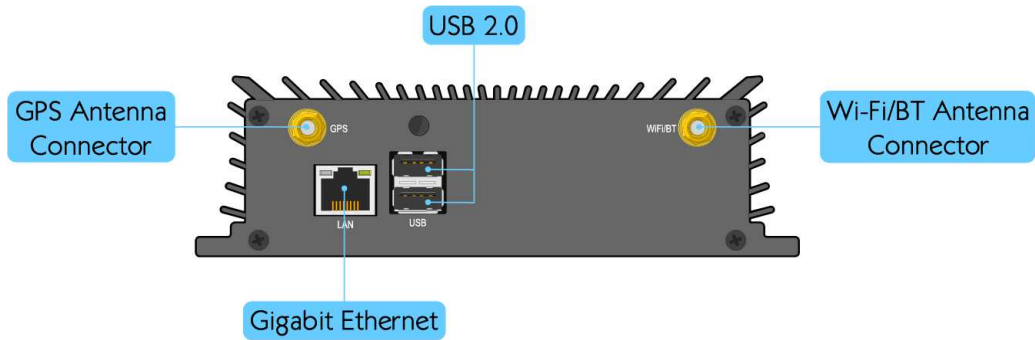

Figure 2: Back panel I/O layout

## 1.4. Product Dimensions

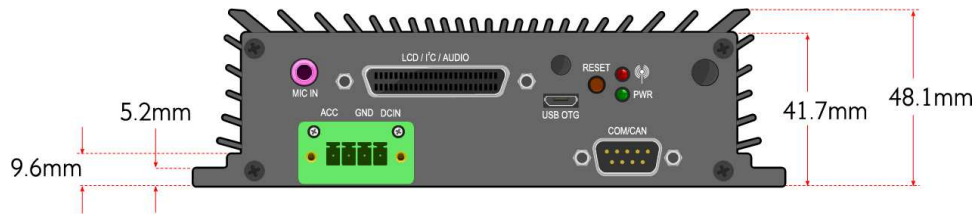

Figure 3: Dimensions of the VIA AMOS-825 (front view)

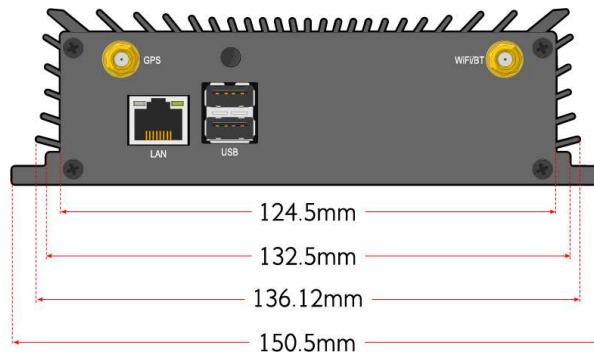

Figure 4: Dimensions of the VIA AMOS-825 (rear view)

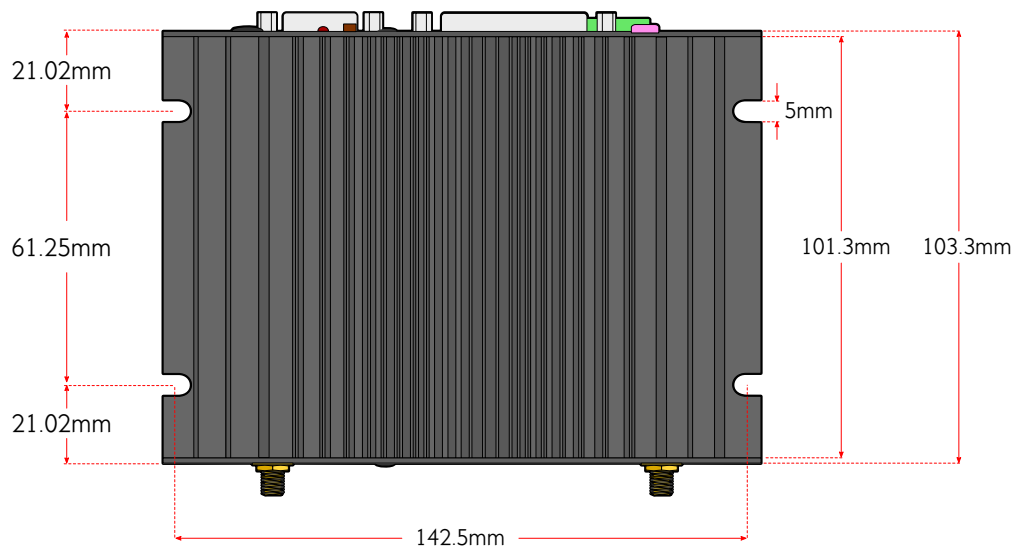

Figure 5: Dimensions of the VIA AMOS-825 (top view)

## 2. External I/O Pin Descriptions and Functionality

This chapter provides information about the VIA AMOS-825's external I/O ports, LED indicators and its functionality.

### 2.1. DC-in Jack

The VIA AMOS-825 comes with a 4-pole Phoenix DC jack on the front panel that carries 9V~36V DC external power input.

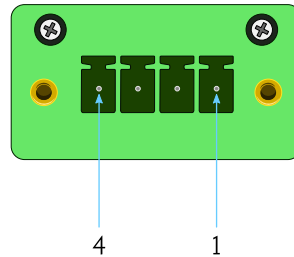

Figure 6: DC-in jack diagram

Pin	Signal
1	9V~36V DC
2	GND
3	NC
4	ACC (Automatic Combustion Control)

Table 1: DC-in jack pinouts

### 2.2. Reset Button

The VIA AMOS-825 comes with a reset button on the front panel. The reset button allows the user to reboot or reset the system forcibly.



Figure 7: Reset button diagram

### 2.3. LED Indicators

There are two LEDs on the front panel that indicates the status of the system power and network connectivity:

- Power LED is green and indicates the status of system's power.
- WPAN/WWAN/WLAN LED is red and indicates the network status of the system.

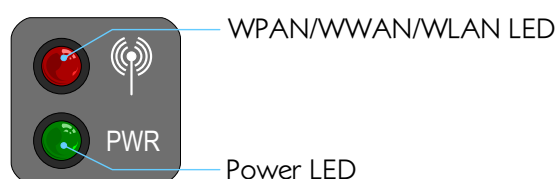

Figure 8: LED indicator diagram

## 2.4. Mic-in Jack

The Mic-in jack receptacle is used to attach a microphone. The jack receptacle can fit a 3.5mm Tip Ring Sleeve (TRS) connector.

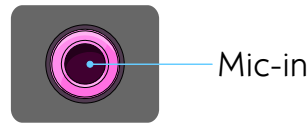

Figure 9: Mic-in jack receptacle diagram

## 2.5. SCSI 50-Pin D-Sub Connector

The VIA AMOS-825 comes with an SCSI 50-pin D-sub connector located on the front panel. The SCSI 50-pin D-sub connector supports the backlight power, dual-channel LVDS, four GPIO, I<sup>2</sup>C, and audio interfaces such as Line-out and Mic-in. The pinouts of the SCSI 50-pin D-sub connector are shown below.

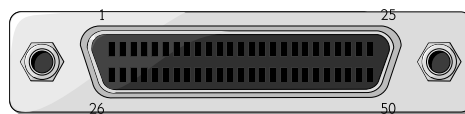

Figure 10: SCSI 50-pin D-sub connector diagram

Pin	Signal	Pin	Signal
1	LVDS1_TX1_NC	26	LVDS1_TX0_PC
2	LVDS1_TX1_PC	27	LVDS1_TX0_NC
3	GND	28	GND
4	LVDS1_TX2_NC	29	LVDS1_CLK_NC
5	LVDS1_TX2_PC	30	LVDS1_CLK_PC
6	GND	31	GND
7	LVDS1_TX3_NC	32	GPIO5
8	LVDS1_TX3_PC	33	GPIO4
9	GND	34	GPIO2
10	LVDS0_TX0_NC	35	GPIO1
11	LVDS0_TX0_PC	36	I2C3_SDA
12	GND	37	3P3V
13	LVDS0_TX1_PC	38	I2C3_SCL
14	LVDS0_TX1_NC	39	DISP0_CONTRAST
15	GND	40	BLT_EN
16	LVDS0_TX2_NC	41	GND
17	LVDS0_TX2_PC	42	IVDD
18	GND	43	IVDD
19	LVDS0_CLK_PC	44	PVDD
20	LVDS0_CLK_NC	45	PVDD
21	GND	46	GND
22	LVDS0_TX3_NC	47	GND_ANALOG
23	LVDS0_TX3_PC	48	HEAD_LEFT
24	GND_ANALOG	49	MIC_IN
25	GND	50	HEAD RIGHT

Table 2: SCSI 50-pin D-sub connector pinouts



## 2.6. Micro USB 2.0 OTG Port

The VIA AMOS-825 comes with a Micro USB 2.0 OTG port (Micro USB Type B connector) located on the front panel. The Micro USB 2.0 OTG port supports OTG (On-The-Go). The pinouts of the Micro USB 2.0 OTG port are shown below.



Figure 11: Micro USB 2.0 OTG port diagram

Pin	Signal
1	VBUS
2	D-
3	D+
4	ID
5	GND

Table 3: Micro USB 2.0 OTG port pinouts



**Note:**

The VIA AMOS-825 is regarded as an USB device by default when connected to an USB host.

## 2.7. COM/CAN Port

The integrated 9-pin COM/CAN port uses a male DE-9 connector. The COM/CAN port support two CAN bus and one COM (TX/RX). The CAN bus supports CAN protocol specification Version 2.0 B while the COM supports TX/RX for debug. The pinouts of the COM/CAN port are shown below.

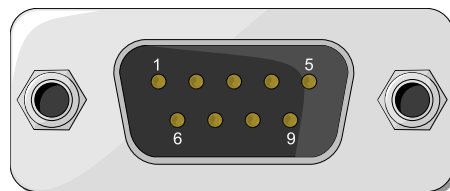

Figure 12: COM/CAN port diagram

Pin	Signal
1	CANH1
2	RX
3	TX
4	CANL2
5	GND
6	CANL1
7	GND
8	CANH2
9	VCC5

Table 4: COM/CAN port pinouts



**Note:**

Do not directly plug a COM cable to the COM/CAN port. Please use the COM/CAN conversion cable when connecting to the COM/CAN port.

## 2.8. USB 2.0 Ports

The VIA AMOS-825 provides two USB 2.0 ports located on the back panel. Each USB port gives complete Plug and Play and hot swap capability for external devices. The USB interface complies with USB UHCI, Rev. 2.0. The pinouts of the USB 2.0 port are shown below.



Figure 13: USB 2.0 port diagram

USB 2.0 port 1		USB 2.0 port 2	
Pin	Signal	Pin	Signal
1	VCC	1	VCC
2	USB1 data-	2	USB2 data-
3	USB1 data+	3	USB2 data+
4	GND	4	GND

Table 5: USB 2.0 ports pinouts

## 2.9. Gigabit Ethernet Port

The VIA AMOS-825 is equipped with a Gigabit Ethernet port that supports high-speed transmission. The Gigabit Ethernet port is using 8 position 8 contact (8P8C) receptacle connector commonly known as RJ-45. It is fully compliant with IEEE 802.3 (10BASE-T), 802.3u (100BASE-TX), and 802.3ab (1000BASE-T) standards. The pinouts of the Gigabit Ethernet port are shown below.

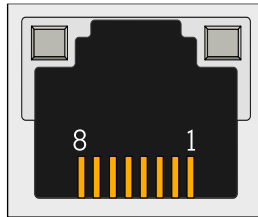

Figure 14: Gigabit Ethernet port diagram

Pin	Signal
1	Signal pair 1+
2	Signal pair 1-
3	Signal pair 2+
4	Signal pair 3+
5	Signal pair 3-
6	Signal pair 2-
7	Signal pair 4+
8	Signal pair 4-

Table 6: Gigabit Ethernet port pinouts

The Gigabit Ethernet port has two individual LED indicators located on the front side to show its Active/Link status and Speed status.

	Link LED (Left LED on RJ-45 port)	Active LED (Right LED on RJ-45 port)
Link Off	LED is off	LED is off
Speed_10Mbit	The LED is always On in Orange color	Flash in Yellow color
Speed_100Mbit	The LED is always On in Orange color	Flash in Yellow color
Speed_1000Mbit	The LED is always On in Orange color	Flash in Yellow color

Table 7: Gigabit Ethernet port LED color definition

## 3. Onboard I/O

This chapter provides information about the onboard I/O on the VIA AMOS-825's mainboard.

### 3.1. MiniPCIe Slot

The VIA AMOS-825 is equipped with a miniPCIe slot for wireless networking options such as a 3G module. The miniPCIe slot is compatible with miniPCIe 2.0 module that is full-length or half-length. The pinouts of the miniPCIe slot are shown below.

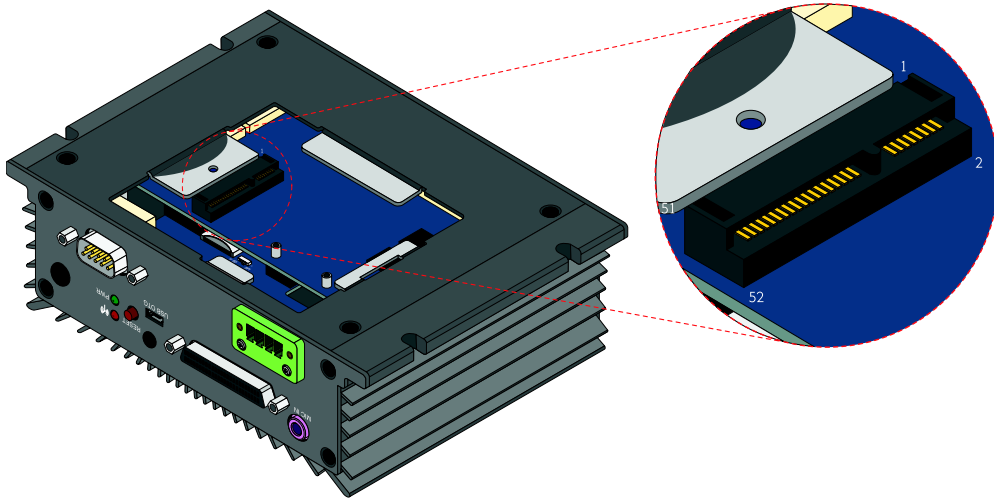

Figure 15: MiniPCIe slot diagram

Pin	Signal	Pin	Signal
1	PCIE_WAKE_B	2	MPCIE_3V3
3	GND	4	GND
5	JTAG_TCK	6	VCC15
7	JTAG_TMS	8	-
9	GND	10	NC
11	PCle_CREFCLKM	12	NC
13	PCle_CREFCLKP	14	NC
15	GND	16	-
17	JTAG_TD1	18	GND
19	JTAG_TD0	20	PCIE_DIS_B
21	GND	22	PCIE_RST_B
23	PCle_CRXM	24	MPCIE_3V3
25	PCle_CRXP	26	GND
27	GND	28	VCC15
29	GND	30	PCle_SMB_CLK
31	PCle_CTXM	32	PCle_SMB_DATA
33	PCle_CTXP	34	GND
35	GND	36	PCIE_USB_DM
37	GND	38	PCIE_USB_DP
39	MPCIE_3V3	40	GND
41	MPCIE_3V3	42	LED_WWAN_B
43	GND	44	LED_WLAN_B
45	JTAG_nTRST	46	LED_WPAN_B
47	JTAG_nSRST	48	VCC15
49	GND	50	GND
51	NC	52	MPCIE_3V3

Table 8: MiniPCIe slot pinouts

## 3.2. Micro SD Card Slot

The VIA AMOS-825 comes with a Micro SD card slot with support for a maximum storage capacity of 32GB. The pinouts of the Micro SD card slot are shown below.

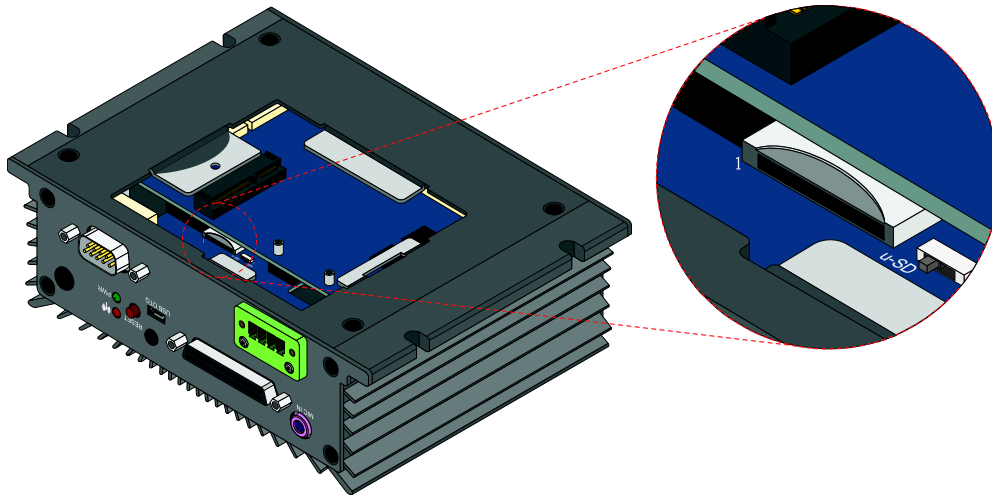

Figure 16: Micro SD card slot diagram

Pin	Signal
1	SD0DATA2
2	SD0DATA3
3	SD0CMD
4	VDD (3.3V)
5	SD0CLK
6	GND
7	SD0DATA0
8	SD0DATA1
9	SD0_CD

Table 9: Micro SD card slot pinouts

## 3.3. Boot Switch

The VIA AMOS-825 is equipped with an onboard boot switch which allows users to boot the device from Micro SD card and SPI. The switch is labeled as "SW1". The default switch position is SPI.

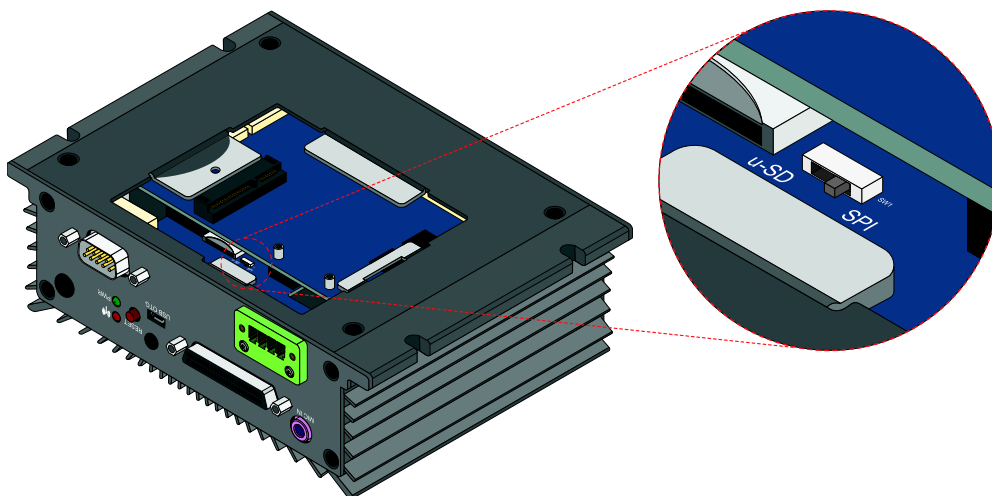

Figure 17: Boot switch diagram

## 4. Hardware Installation

This chapter provides information about hardware installation procedures.

### 4.1. Installing the GPS and Wi-Fi/BT antennas

#### Step 1

Install the GPS and Wi-Fi/BT antennas to the antenna connectors respectively as shown in the figure below.

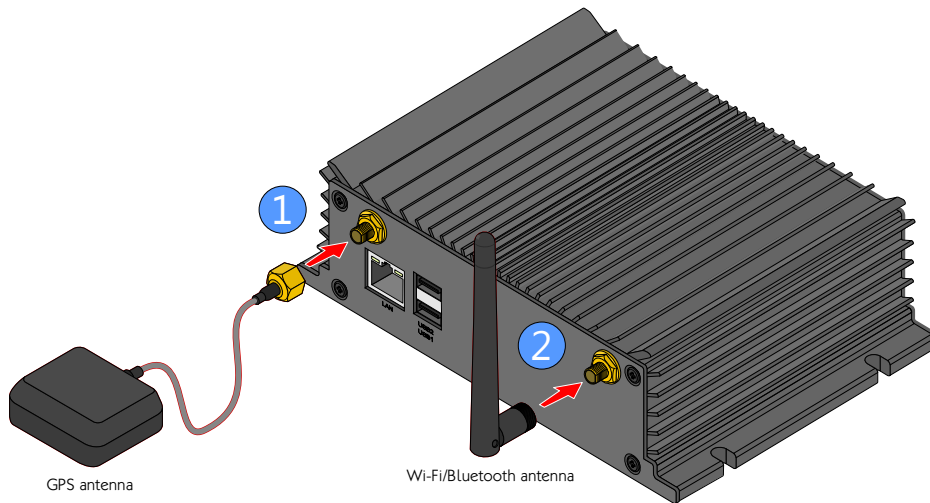

Figure 18: Installing the GPS and Wi-Fi/BT antennas

#### Step 2

Secure the two antennas.

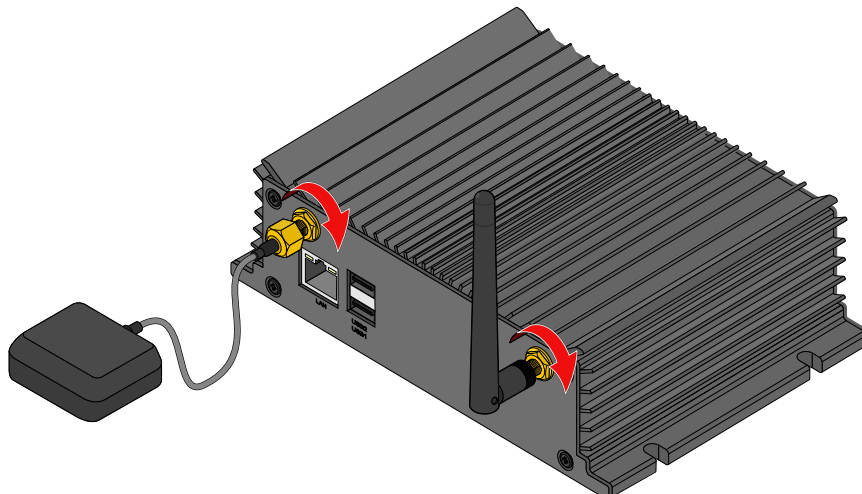

Figure 19: Securing the GPS and Wi-Fi/BT antennas

## 4.2. Installing the Micro SD card

### Step 1

Locate the bottom window plate cover of the chassis. Loosen the screw to remove the cover.

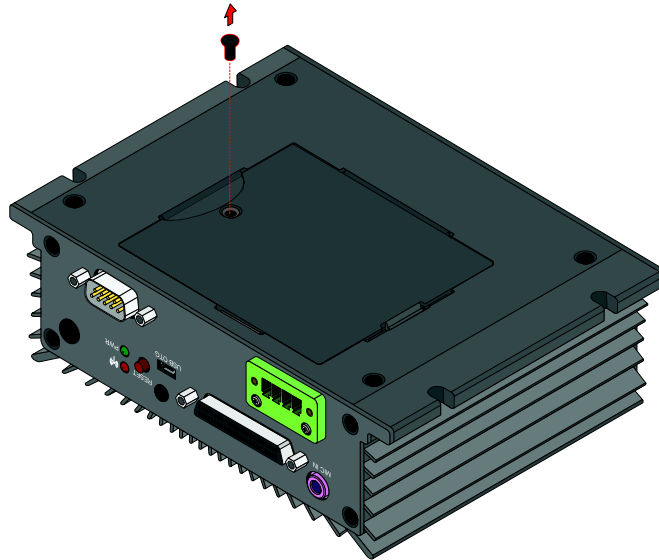

Figure 20: Unscrewing the bottom window plate cover

### Step 2

Remove the bottom window plate cover.

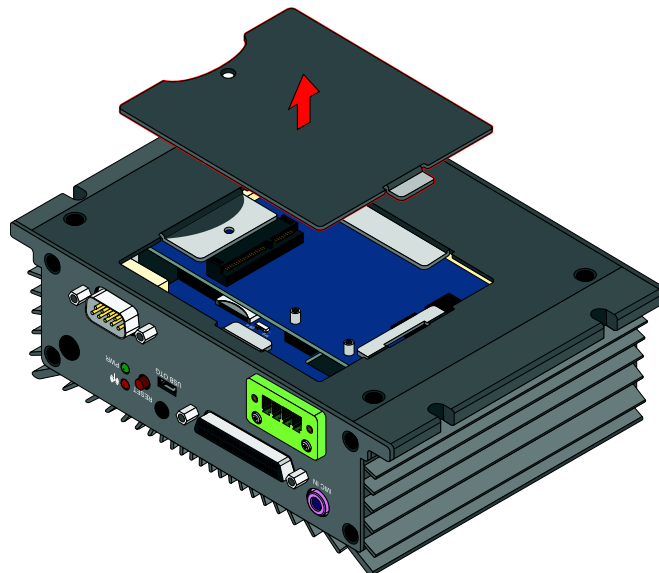

Figure 21: Removing the bottom window plate cover

**Step 3**

Gently insert the Micro SD card into the card slot with the label side facing down then press the card until it locks into place.

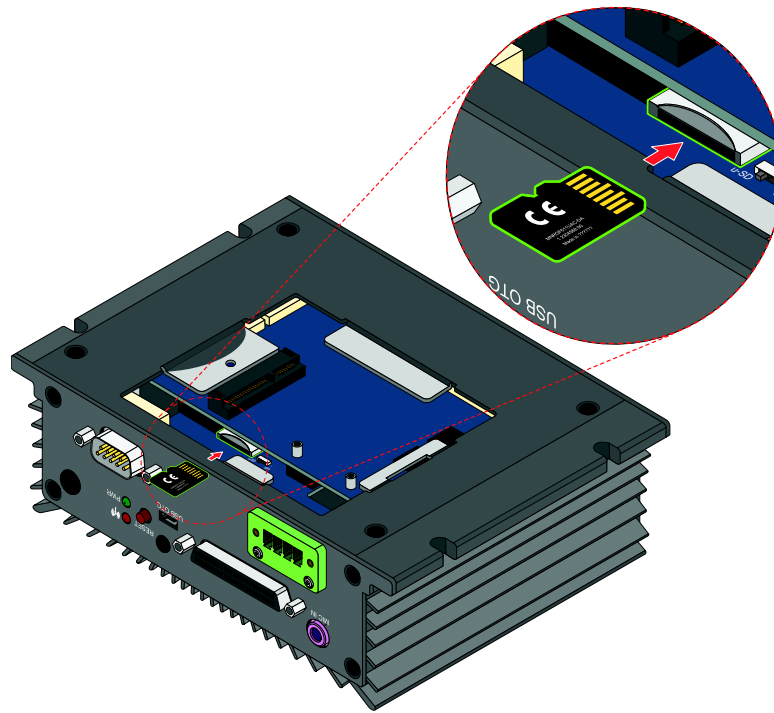

Figure 22: Inserting the Micro SD card



**Note:**

To remove the Micro SD card, press the card to disengage from the slot reader then gently pull out the card.

### 4.3. Installing the rubber feet

Optional rubber feet are available for VIA AMOS-825. It would make the VIA AMOS-825 ideal to any flat surface or desk.

**Step 1**

Locate the area where to install the rubber feet.

**Step 2**

Attach carefully each rubber foot. Firmly press it down to ensure the rubber foot is properly in place.

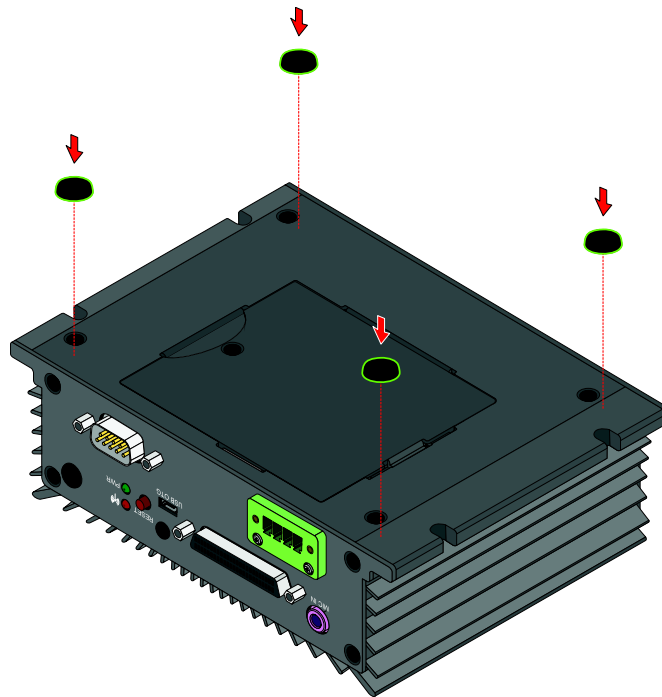

Figure 23: Installing the rubber feet



## 4.4. Installing the COM/CAN Conversion Cable

The COM/CAN conversion cable is a splitter cable used to plug-in to COM/CAN port on the VIA AMOS-825. The COM/CAN conversion cable supports two CAN bus ports and one COM debug port (TX/RX). The pinouts of the supported CAN bus and COM debug ports are shown in below.

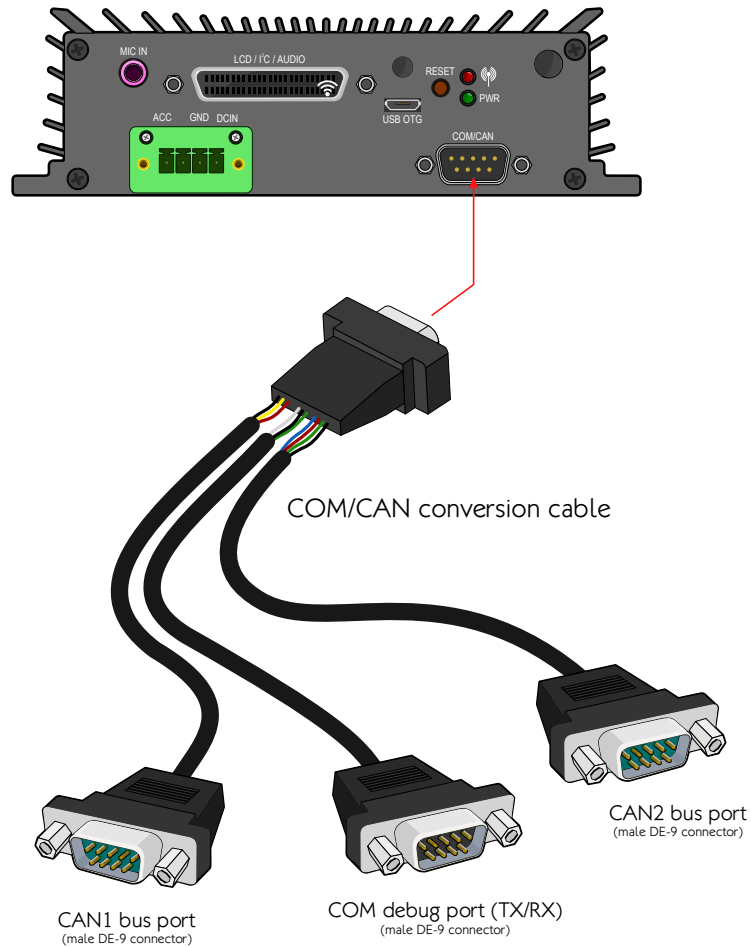

Figure 24: Installing the COM/CAN conversion cable

Pin	Signal
1	NC
2	CANL1
3	NC
4	NC
5	NC
6	GND
7	CANH1
8	NC
9	VCC5

Table 10: CAN1 bus port pinouts

Pin	Signal
1	NC
2	CANL2
3	NC
4	NC
5	NC
6	GND
7	CANH2
8	NC
9	VCC5

Table 11: CAN2 bus port pinouts

Pin	Signal
1	NC
2	COM2_RX
3	COM2_TX
4	NC
5	GND
6	NC
7	NC
8	NC
9	NC

Table 12: COM debug port pinouts

## 4.5. Mounting the VIA AMOS-825

The VIA AMOS-825 has multiple mounting options. Using mounting screws, the VIA AMOS-825 can be mounted on side panel of a car, floor bed, or any flat surface suitable for mounting.



### Reminders:

1. Make sure to remove the rubber feet before mounting the VIA AMOS-825. The rubber feet are not required when mounting the system on the side panel or floor bed of a car.
2. Do not use other types of screws on mounting the VIA AMOS-825 aside from the provided screws to avoid any damages.

### Step 1

Find a suitable surface to mount the VIA AMOS-825.

### Step 2

Drill four holes and ensure the diameters are perfectly matched with the VIA AMOS-825 mounting holes and screws.

### Step 3

Install the VIA AMOS-825 and secure it with four screws.

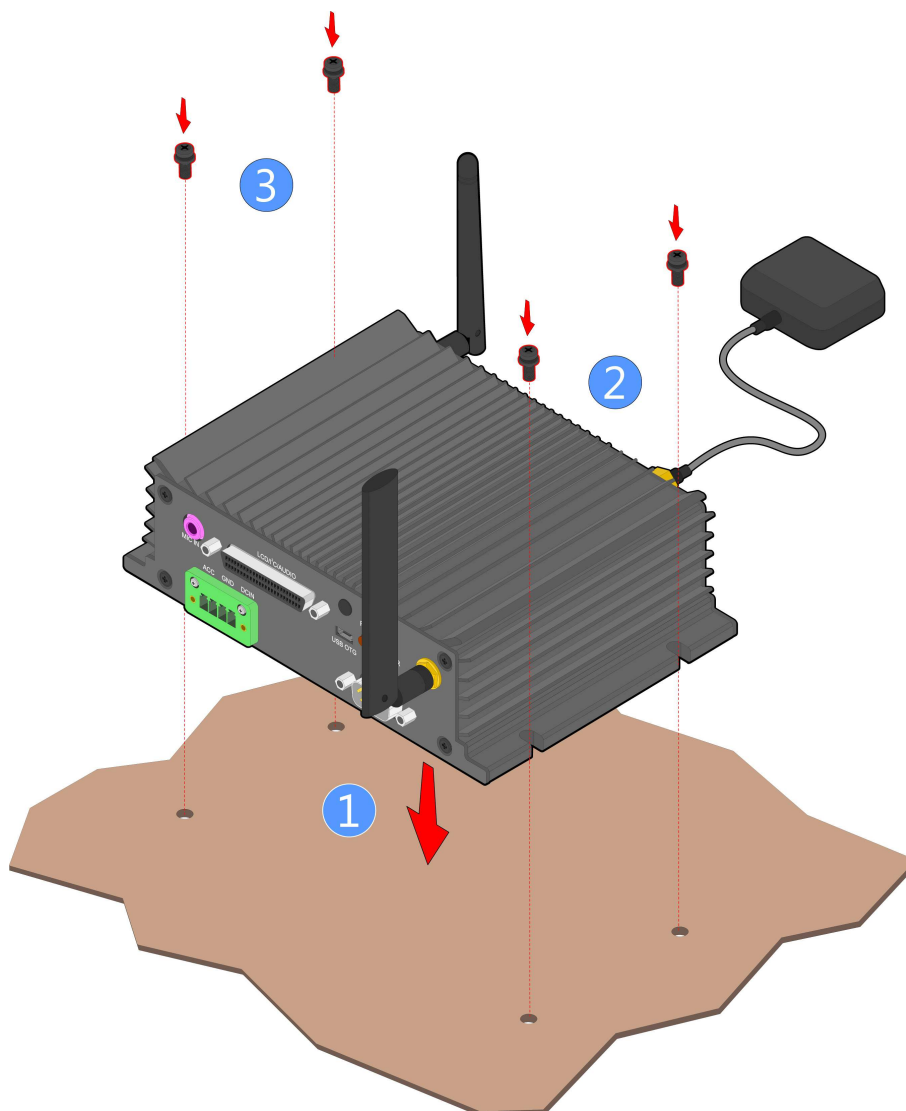

Figure 25: Mounting the VIA AMOS-825

## 5. Software and Technical Support

### 5.1. Android Support

The VIA AMOS-825 features a complete software evaluation image featuring the Android 6.0 operating system.

### 5.2. Technical Support and Assistance

- For utilities downloads and the latest documentation and information about the VIA AMOS-825, please visit our website at <http://www.viatech.com/en/systems/industrial-fanless-pcs/amos-825/>.
- For technical support and additional assistance, always contact your local sales representative or board distributor, or go to <https://www.viatech.com/en/support/driver-support-faq/technical-support/> to fill up the form request.
- For OEM clients and system integrators developing a product for long term production, other code and resources may also be made available. Please visit our website at <https://www.viatech.com/en/about/contact/>.

## Appendix A. Installing Touch Monitor

This chapter provides information on how to connect the touch monitor in VIA AMOS-825.

### A.1. Connecting 7" Projective capacitive touch monitor

#### Step 1

Locate the connector on back of the monitor, and visually inspect the ends of the monitor's cable (SCSI connector cable) to identify the cable heads.

#### Step 2

Connect one end of the monitor's cable (SCSI connector cable) to the LCD monitor. Push the cable head into the connector until the locking latches lock into place. Make sure the cable head is securely connected.

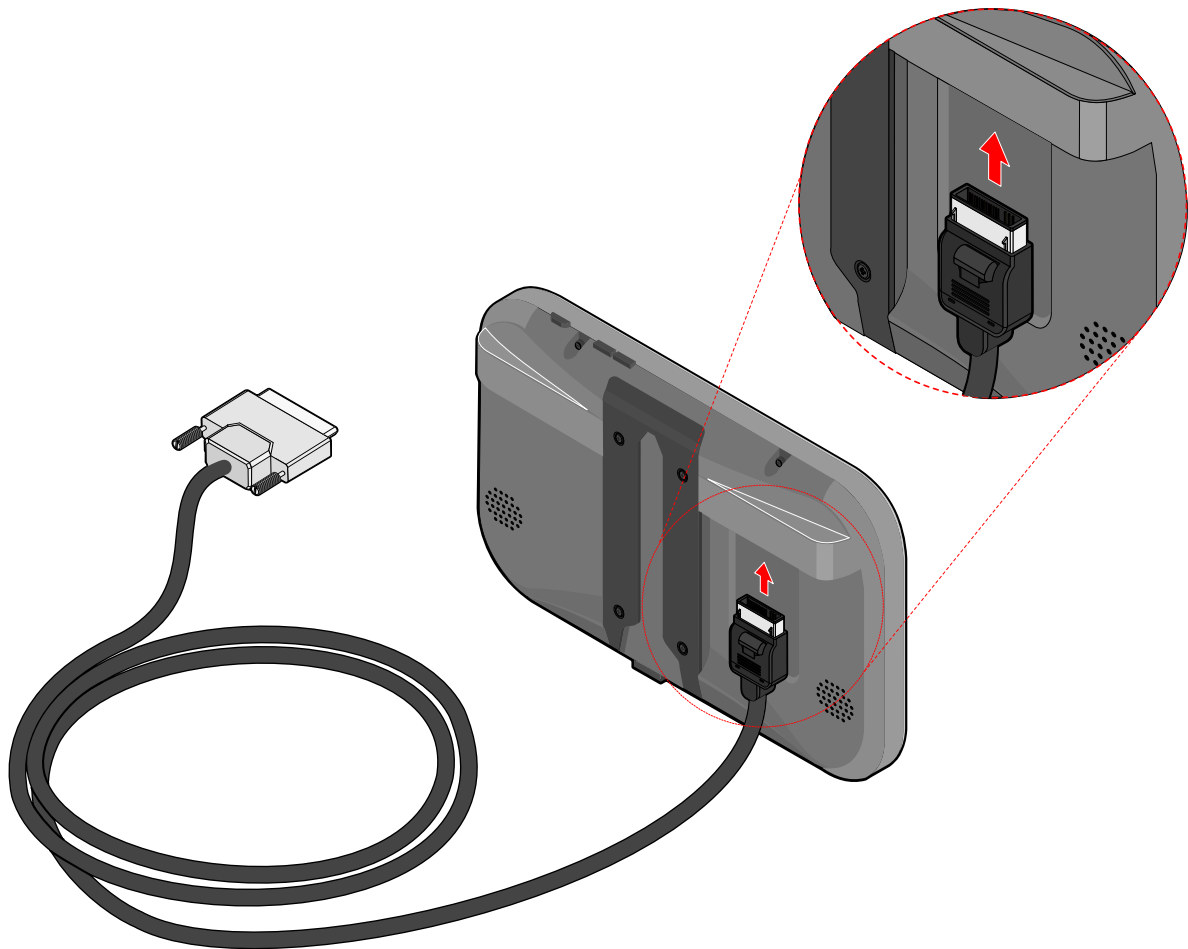

Figure 26: Connecting the other end of the monitor's cable to the touch monitor

**Step 3**

Connect the other end of the monitor's cable (SCSI connector cable) to the SCSI 50-pin D-sub connector on the VIA AMOS-825, and then tighten the thumb screws to secure the connection.

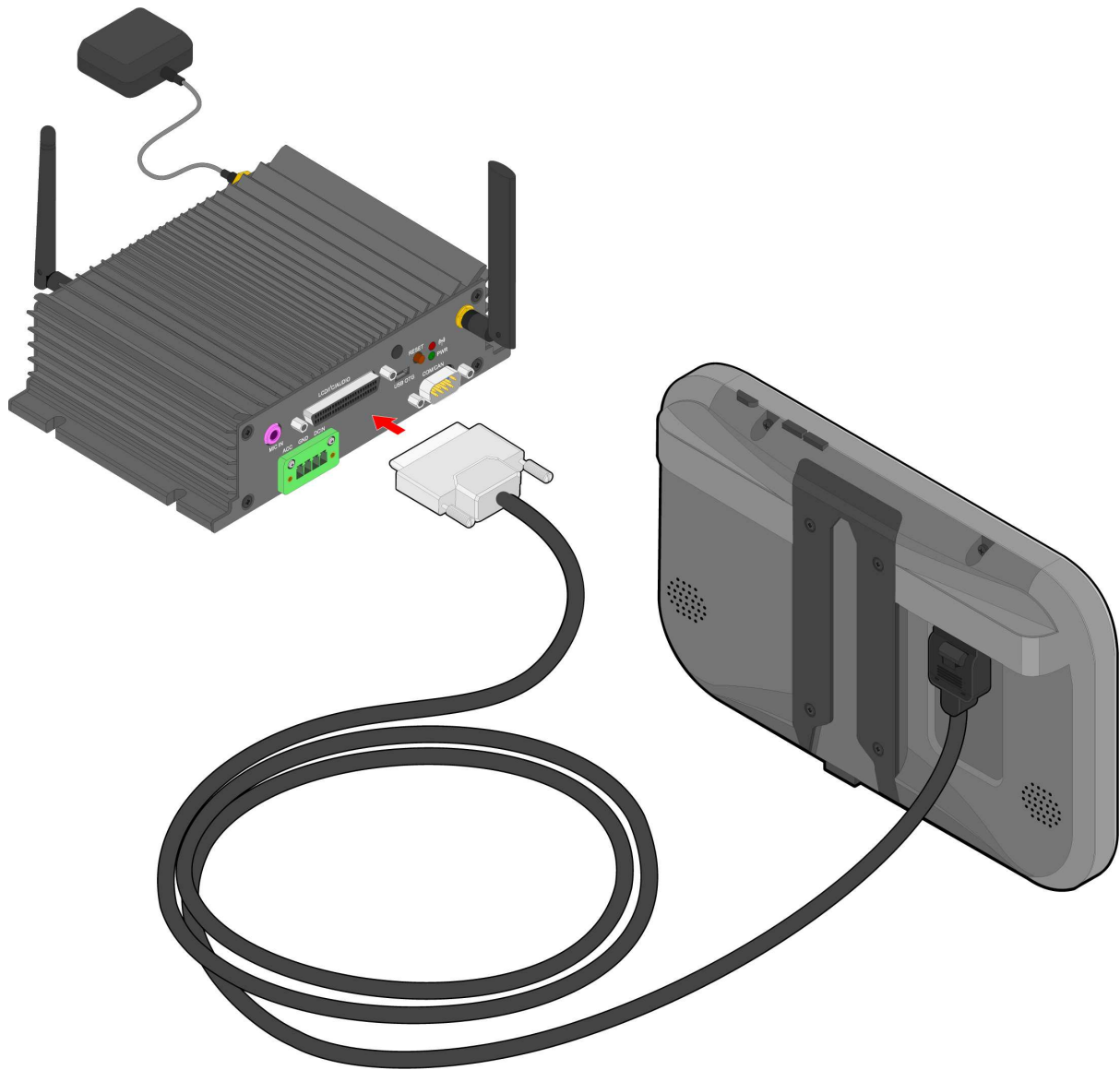

Figure 27: Connecting the monitor's cable to the VIA AMOS-825 system



**Reminder:**  
Make sure to turn off the VIA AMOS-825 before connecting the touch monitor.

## A.2. Unplugging the monitor's cable

### Step 1

Turn off the touch monitor.

### Step 2

Press and hold the lock button on the cable head to release a pair of latches that holds it in place.

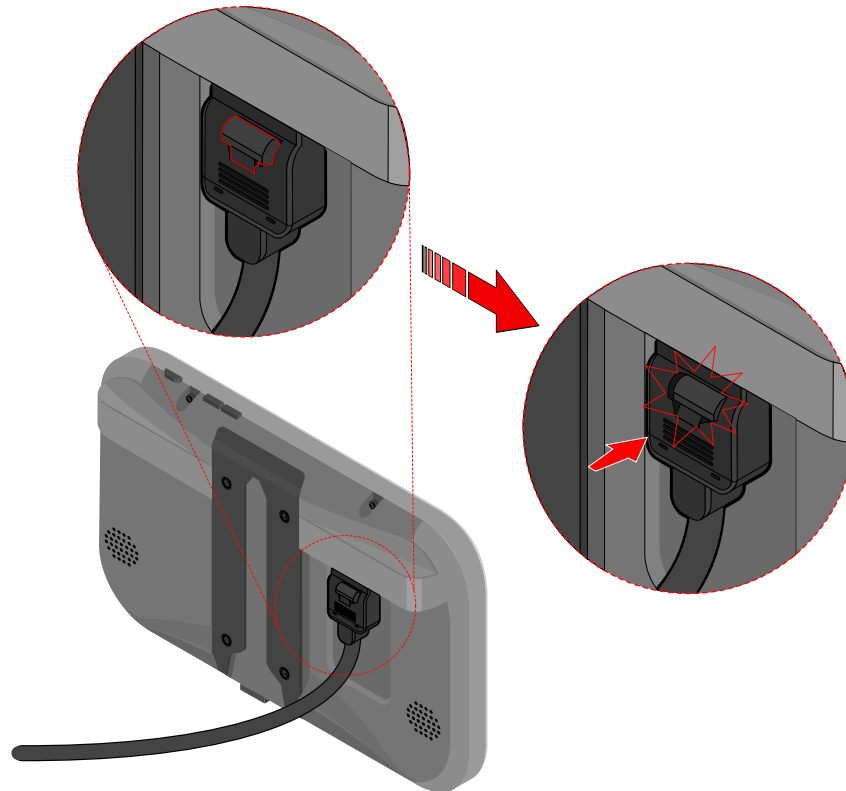

Figure 28: Unlocking the monitor's cable head

### Step 3

Gently unplug the cable head.

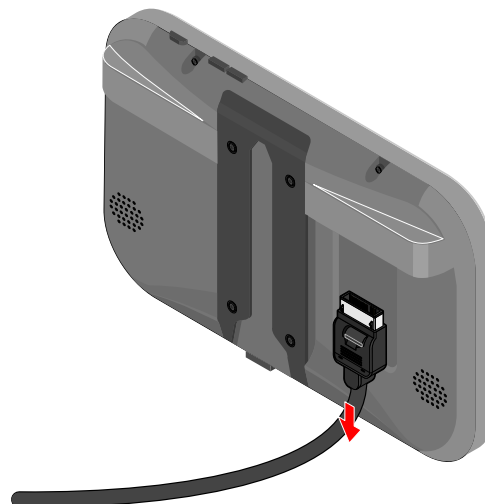

Figure 29: Unplugging the monitor's cable head

## Appendix B. Installing Wireless Accessories

This chapter provides information on how to install the VIA EMIO-2550 miniPCIe mobile broadband module in the VIA AMOS-825.

### B.1. Installing the VIA EMIO-2550 Mobile Broadband Module

#### Step 1

Insert the SIM card on the bottom side of the miniPCIe module (VIA EMIO-2550-00A1).



#### Note:

The Step 1 is only intended for installing of the SIM card on the VIA EMIO-2550-00A1 module. Should the users be using a different module, they can skip Step 1 and go directly to Step 2.

#### Step 2

Align the notch on the miniPCIe module with the protruding wedge on the miniPCIe slot then insert the module at a 30° angle.

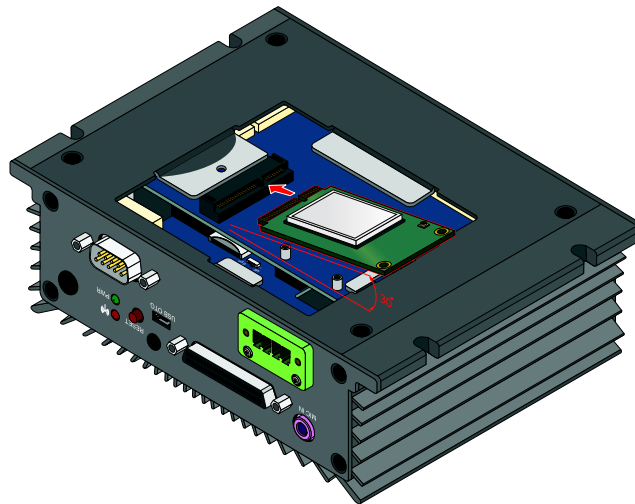

Figure 30: Inserting the VIA EMIO-2550 module

#### Step 3

Once the module has been fully inserted, push down the module until the screw hole aligns with the standoff hole. Then secure the module with the provided screw.

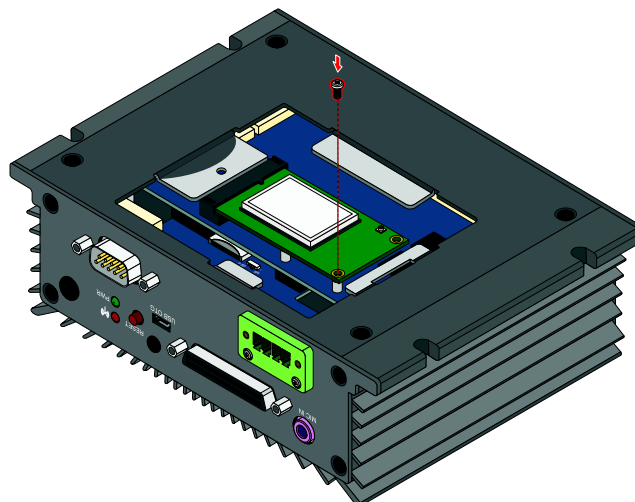

Figure 31: Securing the VIA EMIO-2550 module



**Step 4**

Loosen four screws of the front panel I/O plate.

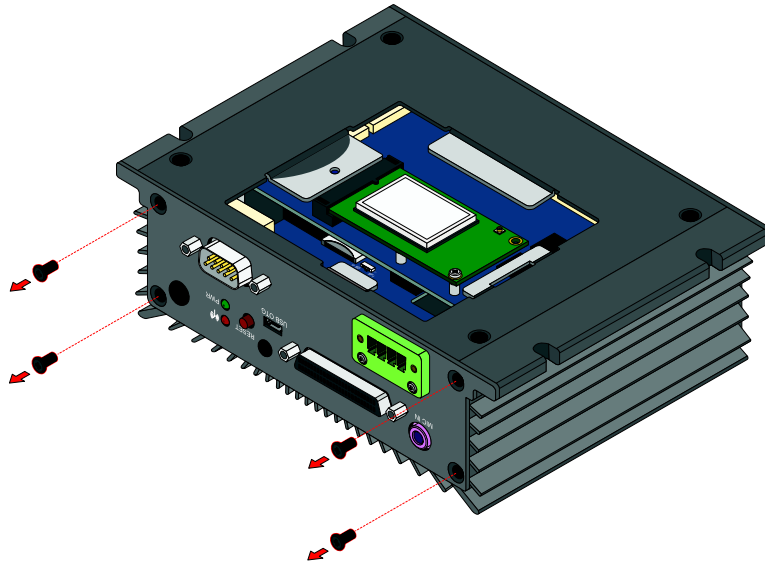

Figure 32: Unscrewing the front panel I/O plate

**Step 5**

Remove the hex standoff screws of COM/CAN port and SCSI 50-pin D-sub connector.

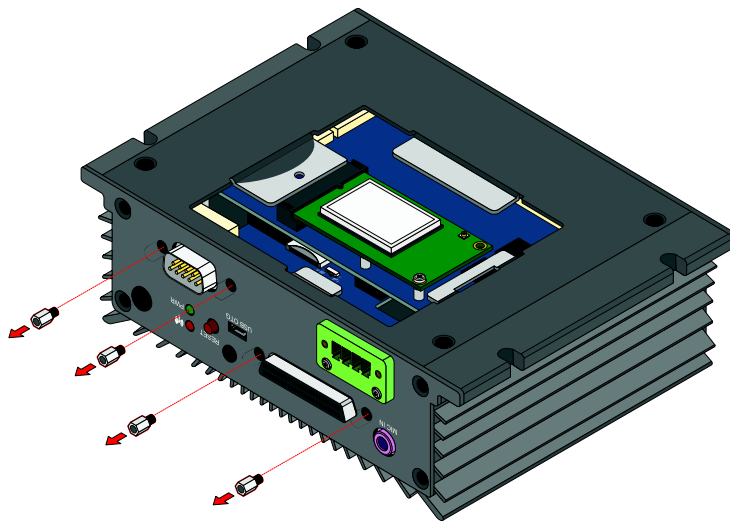

Figure 33: Removing the hex standoff screws

### Step 6

Pull the front panel I/O plate then remove the antenna hole cover.

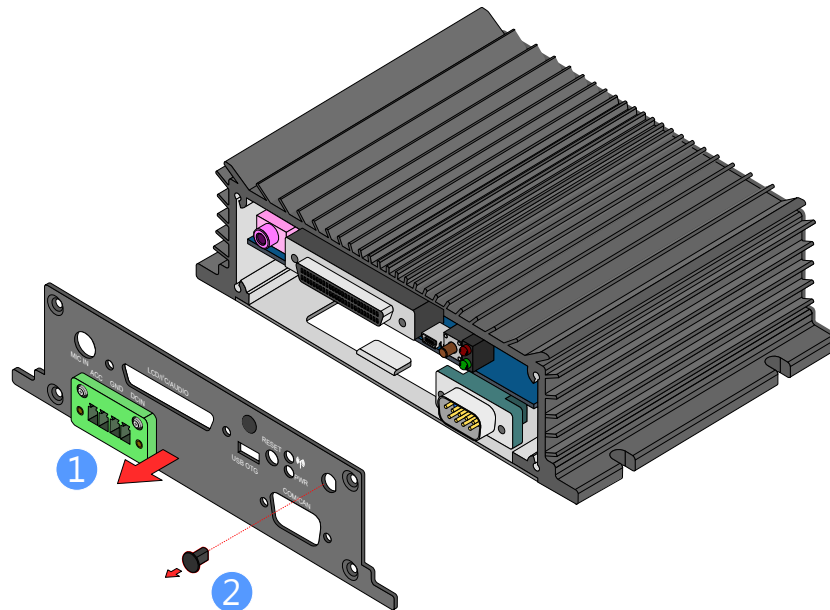

Figure 34: Removing the front panel I/O plate and the antenna hole cover

### Step 7

Insert the 3G antenna cable into the antenna hole from the inside of the front panel I/O plate. Insert the washer, fasten it with the nut, and install the external antenna. Insert the other end of the 3G antenna cable into the available space going down to the bottom side of the chassis. Stretch the cable to reach the installed VIA EMIO-2550 module. Then reinstall the front panel I/O plate.

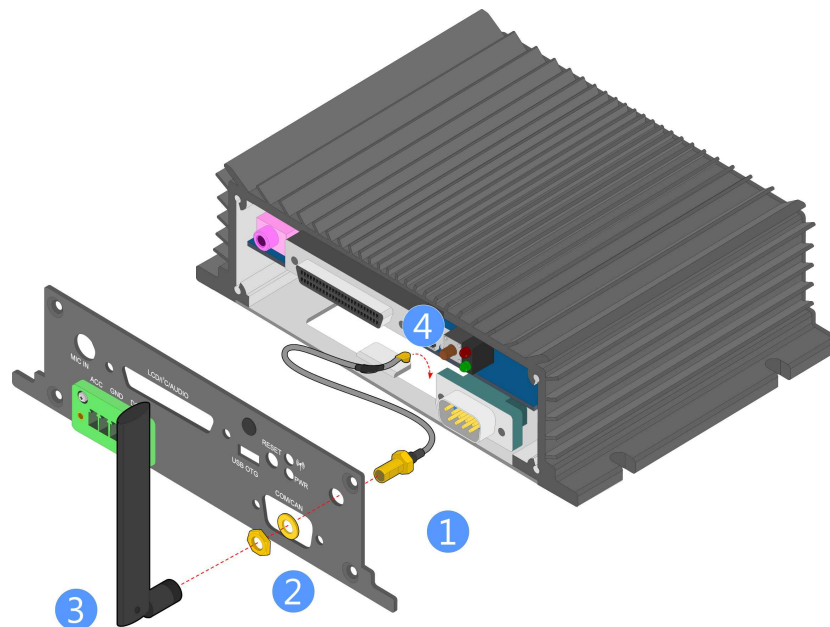

Figure 35: Installing the 3G antenna

**Step 8**

Gently connect the other end of 3G antenna cable to the micro-RF connector labeled "MAIN" on the VIA EMIO-2550 module.

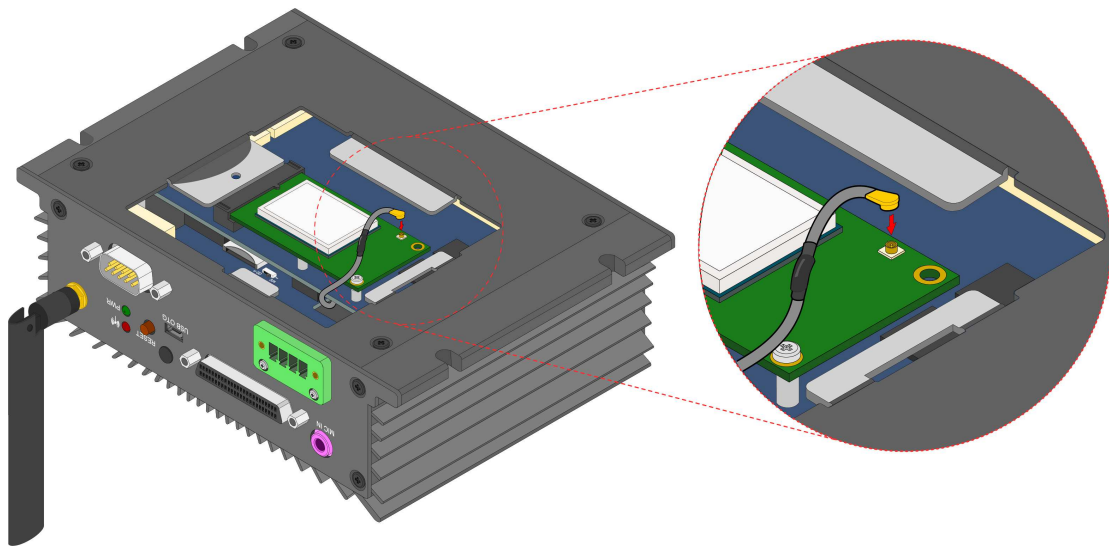

Figure 36: Connecting the 3G antenna cable to the micro-RF connector

**Step 9**

Reinstall the bottom window plate cover.

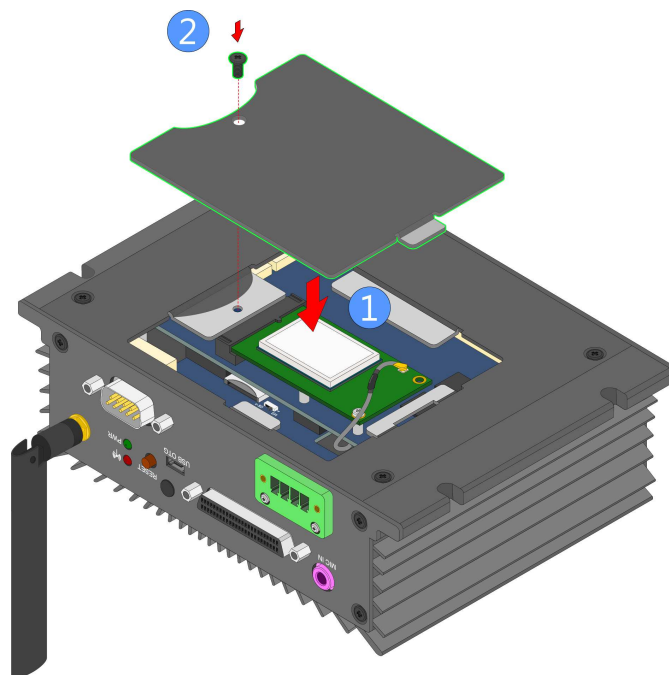

Figure 37: Reinstalling the bottom window plate cover



#### Taiwan Headquarters

1F, 531 Zhong-zheng Road,  
Xindian Dist., New Taipei City 231  
Taiwan

Tel: 886-2-2218-5452  
Fax: 886-2-2218-9860  
Email: [embedded@via.com.tw](mailto:embedded@via.com.tw)



#### USA

940 Mission Court  
Fremont, CA 94539,  
USA

Tel: 1-510-687-4688  
Fax: 1-510-687-4654  
Email: [embedded@viatech.com](mailto:embedded@viatech.com)



#### Japan

3-15-7 Ebisu MT Bldg. 6F,  
Higashi, Shibuya-ku  
Tokyo 150-0011  
Japan

Tel: 81-3-5466-1637  
Fax: 81-3-5466-1638  
Email: [embedded@viatech.co.jp](mailto:embedded@viatech.co.jp)



#### China

Tsinghua Science Park Bldg. 7  
No. 1 Zongguancun East Road,  
Haidian Dist., Beijing, 100084  
China

Tel: 86-10-59852288  
Fax: 86-10-59852299  
Email: [embedded@viatech.com.cn](mailto:embedded@viatech.com.cn)



#### Europe

Email: [embedded@via-tech.eu](mailto:embedded@via-tech.eu)